

19004

ISTRUZIONI DI MONTAGGIO - FITTING INSTRUCTIONS - INSTRUCCIONES PARA SU MONTAJE - MONTAGEANWEISUNGEN - INSTRUCTIONS DE MONTAGE - MONTAGE INSTRUCTIES.

1

PULIRE IL TETTO
 CLEAN THE ROOF
 LIMPIAR EL TECHO
 DACH REINIGEN
 NETTOYER LE TOIT
 DAK SCHOONMAKEN

2

SVITARE
 UNSCREW
 AFLOJAR
 ABSCHRAUBEN
 DEVISSER
 OPENSCHROEVEN

3

MISURE PRECISE
 EXACT DIMENSIONS
 MEDIDAS CORRECTAS
 GENAUE MASSE
 REGLER A LA COTE EXACTE
 EXACTE AFMETINGEN

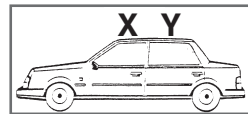

MODELLI AUTO / CARS / COCHES
 WAGEN / VOITURES / AUTO

ANTERIORE FRONT DELANTERO VORDERE AVANT VOORSTE G.	POSTERIORE REAR TRASERO HINTERE ARRIERE ACHTERSTE G.
---	---

X Y

	X	Y
AUDI A4 (01->04)	80 mm	93 mm
AUDI A4 (->00)	115 mm	115 mm
CITROEN AX 5P	135 mm	135 mm
CITROEN SAXO 5P	150 mm	163 mm
DAIHATSU TERIOS "Db" "Dx" (->05)	128 mm	134 mm
DAIHATSU CUORE 5P (->02)	120 mm	120 mm
FORD FIESTA 5P (90 ->01)	135 mm	135 mm
HYUNDAI ACCENT 4-5P (95 ->99)	148 mm	153 mm
MAZDA 121 5P (96 ->)	135 mm	135 mm
MERCEDES Classe A passo corto (->04)	87 mm	107 mm
NISSAN MICRA 5P (92 ->03)	145 mm	153 mm
PEUGEOT 106 5P	155 mm	160 mm
PEUGEOT 205 5P	145 mm	145 mm
SUZUKI ALTO 5P (->01)	106 mm	118 mm

4

A - AVVITARE (A FONDO)
 TO SCREW (DOWN)
 APRETAR (A FONDO)
 FESTSCHRAUBEN
 VISSER (À FOND)
 VASTSCHROEVEN

8 Nm

B - INSERIRE TAPPO SU VITE
 INSERT THE CAP ON THE SCREW
 CUBRIR TORNILLO CON SU PLASTICO
 STOPFEN AUF DIE SCHRAUBE EINSETZEN
 ENFILER LE CAPUCHON SUR LA VIS
 BEVESTIG DE DOP OP DE SCHROEF

5

TAGLIARE
 TO CUT
 CORTAR
 SCHNEIDEN
 COUPER
 SNIJDEN

6

MONTAGGIO GANASCINE
 HOW TO ASSEMBLE THE CLAMPS
 COMO MONTAR LAS FIJACIONES
 ZUSAMMENBAU DER SPANNBACKEN
 MONTAGE PATTE
 MONTAGE VAN DE KLEMMEN

7

OPTIMUM 700 mm

8

CENTRARE IL P. TUTTO SUL TETTO
 CENTRE THE UNIVERSAL BAR
 CARRIER ON THE ROOF
 CENTRAR EL PORTAEQUIPAJES
 SOBRE EL TECHO
 LASTENTRÄGER AUF DEM DACH
 ZENTRIEREN
 CENTRER LE PORTE-TOUT SUR LE TOIT
 PLAATS DE UNIVERSELE DRAGER
 IN HET MIDDEN VAN HET DAK

9

MODELLI CON PREDISPOSIZIONE DELLA CASA AUTO:

CARS WITH PRE-EXISTING FIXING POINT FROM MANUFACTURER
 MODELOS CON PREDISPOSICION DEL FABRICANTE
 AUTOS MIT VOM HERSTELLER VORGESEHENE BEFESTIGUNGSPUNKTE
 VOITURES AVEC POINTS DE RÉPÈRE PRÉVUS PAR LE CONSTRUCTEUR
 AUTO'S MET DOOR DE FABRIKANT VOORZIENE MONTAGEPUNTEN

“À TROUVER SUR LE BATTANT DE LA PORTE OU
 DANS LE MANUAL TECHNIQUE DE LA VOITURE “

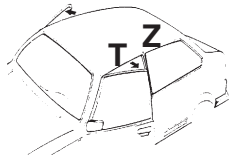

ANTERIORE FRONT DELANTERO VORDERE AVANT VOORSTE G.	POSTERIORE REAR TRASERO HINTERE ARRIERE ACHTERSTE G.
---	---

MODELLI AUTO / CARS / COCHES
 WAGEN / VOITURES / AUTO

	T	Z
AUDI A4 (->00)		
PEUGEOT 106 5P		

AVVITARE
 TO SCREW
 APRETAR
 FESTSCHRAUBEN
 VISSER
 VASTSCHROEVEN

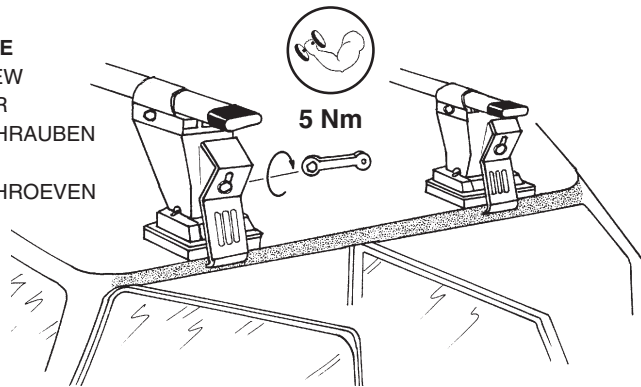

MODELLI SENZA PREDISPOSIZIONE DELLA CASA AUTO:

CARS WITHOUT PRE-EXISTING FIXING POINT
 PARA COCHES SIN PREDISPOSICION DEL FABRICANTE
 AUTOS OHNE VOM HERSTELLER VORGESEHENE BEFESTIGUNGSPUNKTE
 VOITURES SANS POINTS DE RÉPÈRE PRÉVUS PAR LE CONSTRUCTEUR
 AUTO'S ZONDER DOOR DE FABRIKANT VOORZIENE BEVESTIGINGSPUNTEN

10

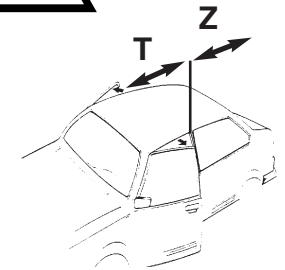

ANTERIORE FRONT DELANTERO VORDERE AVANT VOORSTE G.	POSTERIORE REAR TRASERO HINTERE ARRIERE ACHTERSTE G.
---	---

MODELLI AUTO / CARS / COCHES
 WAGEN / VOITURES / AUTO

	T	Z
AUDI A4 (01->04)	230 mm	330 mm
CITROEN AX 5P	350 mm	350 mm
CITROEN SAXO 5P	280 mm	380 mm
DAIHATSU TERIOS "Db" "Dx" (->05)	330 mm	370 mm
DAIHATSU CUORE 5P (->02)	350 mm	350 mm
FORD FIESTA 5P (90 ->01)	280 mm	300 mm
HYUNDAI ACCENT 4-5P (95 ->99)	350 mm	350 mm
MAZDA 121 5P (96 ->)	280 mm	300 mm
MERCEDES Classe A P. corto (->04)	80 mm	520 mm
NISSAN MICRA 5P (92 ->03)	350 mm	350 mm
PEUGEOT 205 5P	350 mm	350 mm
SUZUKI ALTO 5P (->01)	250 mm	450 mm

AVVITARE
 TO SCREW
 APRETAR
 FESTSCHRAUBEN
 VISSER
 VASTSCHROEVEN

