

19005

ISTRUZIONI DI MONTAGGIO - FITTING INSTRUCTIONS - INSTRUCCIONES PARA SU MONTAJE - MONTAGEANWEISUNGEN - INSTRUCTIONS DE MONTAGE - MONTAGE INSTRUCTIES.

1



PULIRE IL TETTO
 CLEAN THE ROOF
 LIMPIAR EL TECHO
 DACH REINIGEN
 NETTOYER LE TOIT
 DAK SCHOONMAKEN

2

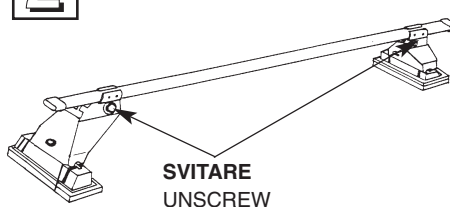

SVITARE
 UNSCREW
 AFLOJAR
 ABSCHRAUBEN
 DEVISSER
 OPENSCHROEVEN

3

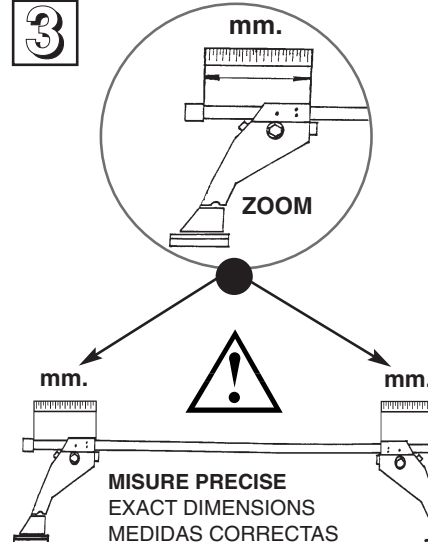

MISURE PRECISE
 EXACT DIMENSIONS
 MEDIDAS CORRECTAS
 GENAU MASSE
 REGLER A LA COTE EXACTE
 EXACTE AFMETINGEN

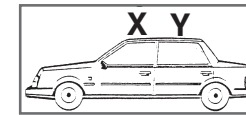

MODELLI AUTO / CARS / COCHES
 WAGEN / VOITURES / AUTO

ANTERIORE FRONT DELANTERO VORDERE AVANT VOORSTE G.	POSTERIORE REAR TRASERO HINTERE ARRIERE ACHTERSTE G.
---	---

	X	Y
AUDI A3 SPORTBACK NO RAILS	80 mm	100 mm
AUDI A3 4P (->02)	119 mm	127 mm
AUDI A3 (->02)	115 mm	135 mm
AUDI 80 (86->)	148 mm	159 mm
AUDI 100 (91->)	115 mm	130 mm
AUDI A6 (-> 96)	83 mm	95 mm
AUDI A6 (97->04)	83 mm	78 mm
DAEWOO LANOS 4-5P	134 mm	138 mm
DAEWOO NUBIRA 4-5P (->02)	118 mm	123 mm
DAEWOO KALOS 5P	95 mm	109 mm
DAEWOO EVANDA	79 mm	89 mm
DAIHATSU SIRION 5P (->05)	94 mm	105 mm
FORD NEW FIESTA 5P (08->)	84 mm	95 mm
KIA SHUMA	119 mm	119 mm
HYUNDAI ACCENT 4-5P (00->)	113 mm	110 mm
HONDA ACCORD 5P (95->02)	118 mm	110 mm
HONDA CIVIC 5P (01->06)	93 mm	96 mm
MERCEDES Classe A P. lungo (->04)	94 mm	111 mm
ROVER 600	118 mm	113 mm
ROVER 75	80 mm	80 mm
SEAT AROSA	102 mm	126 mm
SUZUKI ALTO 5P (02->)	168 mm	184 mm
VOLVO S 40 (->04)	123 mm	129 mm
VOLVO V 40	115 mm	135 mm
V W PASSAT 5P (88-> 96)	120 mm	145 mm
V W PASSAT 5P (97->99)	93 mm	93 mm
V W PASSAT 5P (00->05)	77 mm	82 mm
V W PASSAT SW NO RAILS (00->05)	85 mm	91 mm
VW LUPO	96 mm	120 mm

4

A - AVVITARE (A FONDO)
 TO SCREW (DOWN)
 APRETAR (A FONDO)
 FESTSCHRAUBEN
 VISSER (À FOND)
 VASTSCHROEVEN

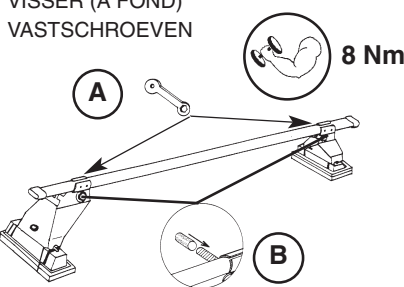

8 Nm

B - INSERIRE TAPPO SU VITE
 INSERT THE CAP ON THE SCREW
 CUBRIR TORNILLO CON SU PLASTICO
 STOPFEN AUF DIE SCHRAUBE EINSETZEN
 ENFILER LE CAPUCHON SUR LA VIS
 BEVESTIG DE DOP OP DE SCHROEF

5

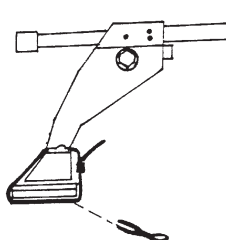

TAGLIARE
 TO CUT
 CORTAR
 SCHNEIDEN
 COUPER
 SNIJDEN

5

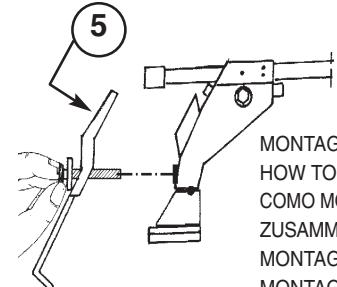

6

MONTAGGIO GANASCINE
 HOW TO ASSEMBLE THE CLAMPS
 COMO MONTAR LAS FIJACIONES
 ZUSAMMENBAU DER SPANNBACKEN
 MONTAGE PATTE
 MONTAGE VAN DE KLEMMEN

7

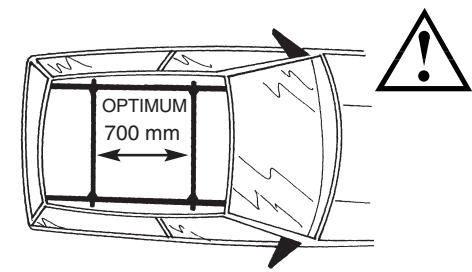

OPTIMUM 700 mm

8

CENTRARE IL P. TUTTO SUL TETTOCENTRE THE UNIVERSAL BAR
CARRIER ON THE ROOFCENTRAR EL PORTAEQUIPAJES
SOBRE EL TECHOLASTENTRÄGER AUF DEM DACH
ZENTRIEREN

CENTRER LE PORTE-TOUT SUR LE TOIT

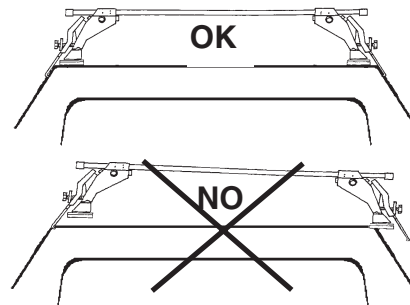
PLAATS DE UNIVERSELE DRAGER
IN HET MIDDEN VAN HET DAK**MODELLI SENZA PREDISPOSIZIONE DELLA CASA AUTO:**

CARS WITHOUT PRE-EXISTING FIXING POINT

PARA COCHES SIN PREDISPOSICION DEL FABRICANTE

AUTOS OHNE VOM HERSTELLER VORGESEHENE BEFESTIGUNGSPUNKTE

VOITURES SANS POINTS DE RÉPÈRE PRÉVUS PAR LE CONSTRUCTEUR

AUTO'S ZONDER DOOR DE FABRIKANT VOORZIENE BEVESTIGINGSPUNTEN

9B

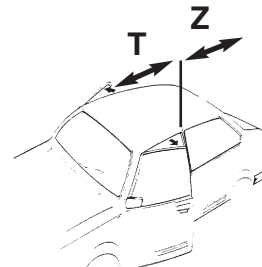

ANTERIORE
FRONT
DELANTERO
VORDERE
AVANT
VOORSTE G.

POSTERIORE
REAR
TRASERO
HINTERE
ARRIERE
ACHTERSTE G.

MODELLI AUTO / CARS / COCHES
WAGEN / VOITURES / AUTO

AUDI A3 5P SPORTBACK NO RAILS	200 mm	500 mm
AUDI A3 (->02)	270 mm	420 mm
DAEWOO LANOS 4-5P	300 mm	300 mm
DAEWOO NUBIRA 4-5P (->02)	260 mm	310 mm
DAEWOO KALOS 5P	250 mm	450 mm
DAEWOO EVANDA	200 mm	400 mm
DAIHATSU SIRION 5P (->05)	300 mm	400 mm
FORD NEW FIESTA 5P (08->)	200 mm	500 mm
KIA SHUMA	270 mm	320 mm
MERCEDES Classe A P. lungo (->04)	180 mm	520 mm
ROVER 75	280 mm	360 mm
SUZUKI ALTO 5P (02->)	250 mm	450 mm
VOLVO S 40 (->04)	220 mm	350 mm
VOLVO V 40	150 mm	520 mm

MODELLI CON PREDISPOSIZIONE DELLA CASA AUTO:

CARS WITH PRE-EXISTING FIXING POINT FROM MANUFACTURER

MODELOS CON PREDISPOSICION DEL FABRICANTE

AUTOS MIT VOM HERSTELLER VORGESEHENE BEFESTIGUNGSPUNKTE

VOITURES AVEC POINTS DE RÉPÈRE PRÉVUS PAR LE CONSTRUCTEUR

AUTO'S MET DOOR DE FABRIKANT VOORZIENE MONTAGEPUNTEN

9A

“À TROUVER SUR LE BATTANT DE LA PORTE OU
DANS LE MANUAL TECHNIQUE DE LA VOITURE “

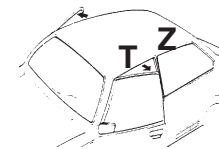

MODELLI AUTO / CARS / COCHES
WAGEN / VOITURES / AUTO

ANTERIORE
FRONT
DELANTERO
VORDERE
AVANT
VOORSTE G.

POSTERIORE
REAR
TRASERO
HINTERE
ARRIERE
ACHTERSTE G.

AUDI A3 4P (->02)	T	Z
AUDI 80 (86 ->)	T	Z
AUDI 100 (91 ->)	T	Z
AUDI A6 (-> 96)	T	Z
AUDI A6 (97 ->04)	T	Z
HONDA ACCORD 5P (95 ->02)	T	Z
HONDA CIVIC 5P (01 ->06)	T	Z
HYUNDAI ACCENT 4-5P (00->06)	T	Z
ROVER 600	T	Z
SEAT AROSA	T	Z
VW PASSAT 5P (88 -> 96)	T	Z
VW PASSAT 5P (97 ->99) - (00->05)	T	Z
VW PASSAT SW NO RAILS (00->05)	T	Z
VW LUPO	T	Z

10



5 Nm

AVVITARE
TO SCREW
APRETAR
FESTSCHRAUBEN
VISSER
VASTSCHROEVEN

